

Eagle is a market leader in the supply, installation and design of PAS 68 gates, bollards and blockers. Eagle also design and manufacture a comprehensive range of LPS1175 Turnstiles for the security sector. Built on a 25 year reputation of providing unique solutions for automated gate industry the company has successfully installed and maintained security solutions for Power Stations, Police, Banks, Hospitals, Schools and Councils.

The Eagle security rated turnstile has also been tested to LPS1175 issue 8

Designed as a single up to SR4 and double to SR3

The turnstile can be constructed in sections allowing the system to be easily shipped and assembled on site.

In-house design team with CAD technology can develop a system bespoke to your requirements.

Wylie Advanced Type 430A-200 Single Full Height Security Turnstile



CPNI®
Centre for the Protection
of National Infrastructure
*Approved for UK Government use,
for details contact CPNI*

The Wylie Advanced Type 430A-200 Single Full Height Security Turnstile has been tested and approved for UK Government use. The tool category is for deliberate forced entry of well protected premises using bodily physical force and a wide selection of attack options. The turnstile is designed to be surface mounted for rapid deployment.

Key Features

- 90° Locking head mechanism, electrically released in both directions
- Rotor sensing relays to provide a voltage free contact following the rotation of the rotor in either direction
- Status light LED panels to indicate when to proceed
- 240V AC mains supply 2 amp
- Fail locked on power failure
- Walkway canopy with down light
- Side panels clad in galvanised weld mesh (this is see through for CCTV)
- Bolts directly onto concrete base
- Finish powder coated standard RAL colour
- Can be assembled on site, if delivered flat pack



Eagle Automation Systems Ltd

Focused on Protection and Security

NSPlus

riba
product
selector

Eagle Automation Ltd

ENGINEERED SOLUTIONS

Eagle Automation Systems Ltd is one of the leading manufacturers of commercial security gates in the UK. Our market leading range of in house manufactured and designed PAS 68 gates is now specified by some of the leading blue chip organisations in the country.

TECHNICAL SUPPORT

Our maintenance and service back up is second to none. Fully trained engineers with the latest equipment and maintenance software specifically written for the security gate industry ensure services are carried out on a regular and timely basis.

Eagle Automation Systems Ltd

Unit 5 New House Farm

Vicarage Lane

North Weald

Essex

CM16 6AP

T:+44 (0)1992 524800

www.eagleautogate.co.uk

Wylfe Advanced Type 430A-200 Single Full Height Security Turnstile

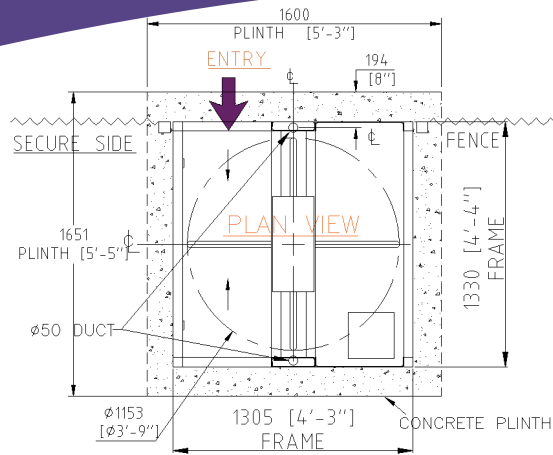

Compliance

- Centre for the Protection of National Infrastructure (CPNI)
- BS EN ISO9001:2015

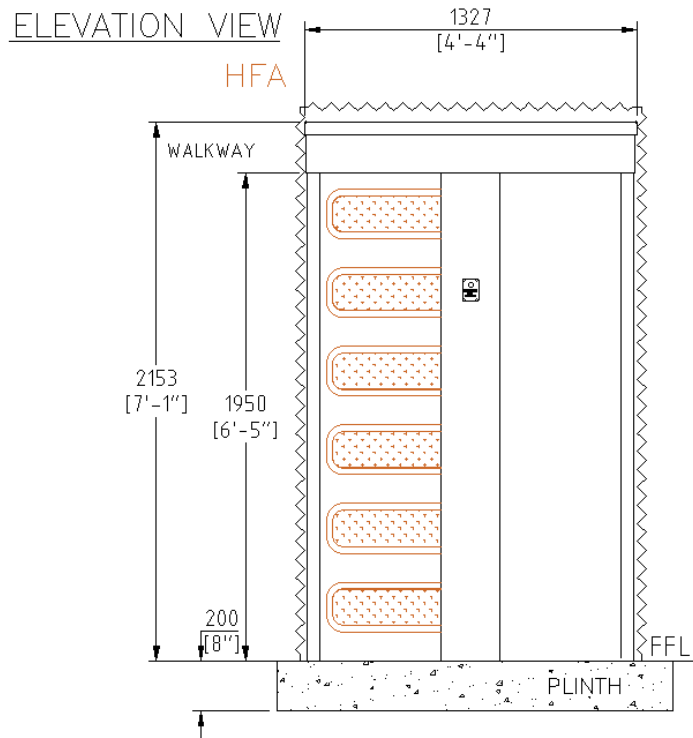

CPNI®

Centre for the Protection
of National Infrastructure

Approved for UK Government use,
for details contact CPNI



Eagle Automation Systems Ltd

Focused on Protection and Security

